

AHKX24-MFT-100

Proportional Control, Electronic Fail-Safe, Linear Stroke, 24V, Multi-Function Technology®



MFT
MULTI-FUNCTION TECHNOLOGY®



Technical Data	AHKX24-MFT-100
Power supply	24 VAC ±20% 50/60Hz 24 VDC ±10%
Power consumption	11W (3W)
Transformer sizing	22VA (class 2 power source)
Electrical Connection	18 GA plenum rated cable ½" conduit connector protected NEMA 2 (IP54) 3 ft [1m] 10 ft [3m] 16 ft [5m]
Overload protection	electronic throughout the full stroke
Operation range Y	2 to 10 VDC, 4 to 20mA (default) variable (VDC,PWM, floating point, on/off)
Input impedance	100kΩ (0.1 mA), 500Ω 1500Ω (PWM, floating point, on/off)
Feedback output U	2 to 10 VDC, 0.5mA max, VDC variable
Linear stroke	4" [100mm]
Linear force	101 lbf [450 N]
Direction of rotation	reversible with switch
Fail-Safe position	adjustable with dial or tool 0 to 100% in 10% increments
Manual override	external push button
Running time	normal operation 150 seconds per 4" [100mm] (default) fail-safe 35 seconds per 4" [100mm]
Humidity	5 to 95% RH non-condensing (EN 60730-1)
Ambient temperature	-22°F to +122°F [-30°C to +50°C]
Storage temperature	-40°F to +176°F [-40°C to +80°C]
Housing	NEMA2, IP54, UL enclosure type 2
Housing material	UL94-5VA
Agency list	cULus acc. to UL 60730-1A/-2-14 CAN/CSA E60730-1:02 CE acc. to 2004/108/EC and 2006/95/EC
Noise level	< 45dB(A)
Servicing	maintenance free
Quality standard	ISO 9001
Weight	3.40 lbs [1.50 kg]
Initial charge	5 to 26 seconds
Bridge time	programmable 0-10 second (2 seconds default) delay before fail-safe activates

Linear force min. 101 lbf.

Application

For fail-safe, proportional control of dampers in HVAC systems. Actuator sizing should be done in accordance with the damper manufacturer's specifications. A feedback signal is provided for position indication.

Default/Configuration

Default parameters for 2 to 10 VDC applications of the AHK..-MFT actuator are assigned during manufacturing. If required, custom versions of the actuator can be ordered. The parameters noted in the Technical Data table are variable. These parameters can be changed by three means:

- Pre-set or custom configurations from Belimo.
- Configurations set by the customer using the most current MFT PC tool software application.
- Handheld ZTH-GEN.

Operation

The AHKX24-MFT-100 provides a 4 inch linear stroke. The stroke of the gear rack can be adjusted on both sides in increments of 0.8 inches [20mm] with the mechanical end stops. When reaching the damper or actuator end position the actuator automatically stops. The gear can be manually disengaged by pressing the button located on the actuator cover. The AHKX24-MFT-100 actuator uses a brushless DC motor controlled by an Application Specific Integrated Circuit (ASIC). The ASIC monitors and controls the actuator rotation and provides a digital rotation sensing (DRS) function to prevent damage to the actuator in a stall condition. Power consumption is reduced in a holding mode. The actuator is electronically protected against overload. The anti-rotation strap supplied with the actuator will prevent lateral movement.

Fail-Safe Indication

LED status indicator lights sequence:

Yellow off / Green on: operation ok, no faults

Yellow off / Green blinking: fail-safe mechanism is active

Yellow on / Green off: fault is detected

Yellow off / Green off: not in operation / capacitors charging

Yellow on / Green on: adaption running

Yellow blinking / Green on: communication with programming tool

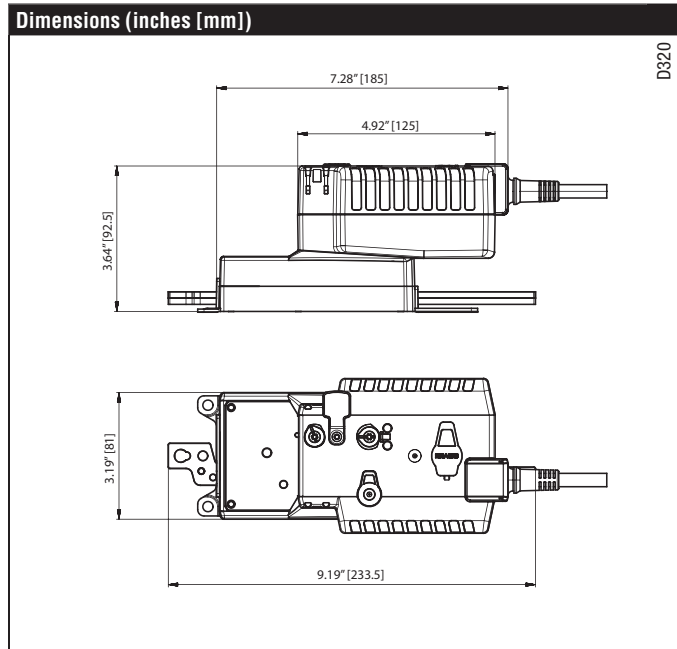

PT10412 - 05/13 - Subject to change. © Belimo Aircontrols (USA), Inc.

Accessories

Z-DS1	Rotary Support to Compensate Lateral Forces
Z-KSA	Linear Coupling
ZG-R01	Resistor for 4 to 20 mA Conversion
ZG-X40	Transformer

Note: When using AHKX24-MFT-100 actuators, only use accessories listed on this page.

Typical Specification

Proportional control damper actuators shall be electronic type, with integrated linear stroking arm. Actuators must provide control in response to a control input from an electronic controller or positioner. Actuators shall have brushless DC motor technology and be protected from overload at all angles of rotation. Actuators shall have reversing switch and manual override on the cover. Run time shall be constant and independent of torque. Actuators shall be cULus listed, have a 5-year warranty, and be manufactured under ISO 9001 International Quality Control Standards. Actuators shall be as manufactured by Belimo.

Wiring Diagrams

✂️ INSTALLATION NOTES

- 1 Provide overload protection and disconnect as required.
- 2 **CAUTION Equipment Damage!**
Actuators may be connected in parallel if not mechanically mounted to the same shaft. Power consumption and input impedance must be observed.
- 3 Actuators may also be powered by 24 VDC.
- 4 Position feedback cannot be used with Triac sink controller. The actuator internal common reference is not compatible.
- 5 Control signal may be pulsed from either the Hot (source) or the Common (sink) 24 VAC line.
- 8 Contact closures A & B also can be triacs. A & B should both be closed for triac source and open for triac sink.
- 9 For triac sink the common connection from the actuator must be connected to the hot connection of the controller.

📄 APPLICATION NOTES

◆ The ZG-R01 500 Ω resistor may be used.

⚠️ **WARNING Live Electrical Components!**
During installation, testing, servicing and troubleshooting of this product, it may be necessary to work with live electrical components. Have a qualified licensed electrician or other individual who has been properly trained in handling live electrical components perform these tasks. Failure to follow all electrical safety precautions when exposed to live electrical components could result in death or serious injury.

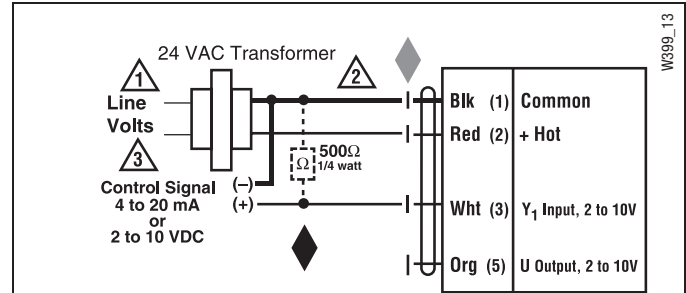

VDC/4-20 mA

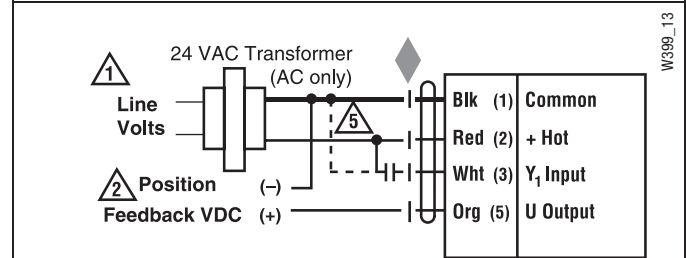

PWM

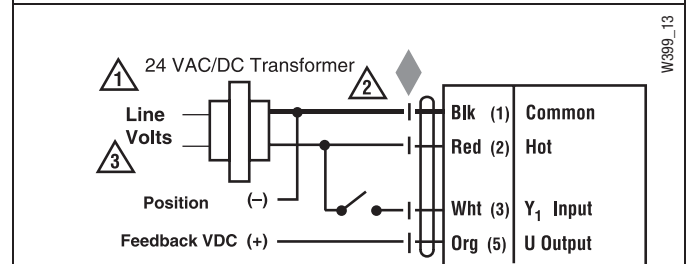

On/Off control

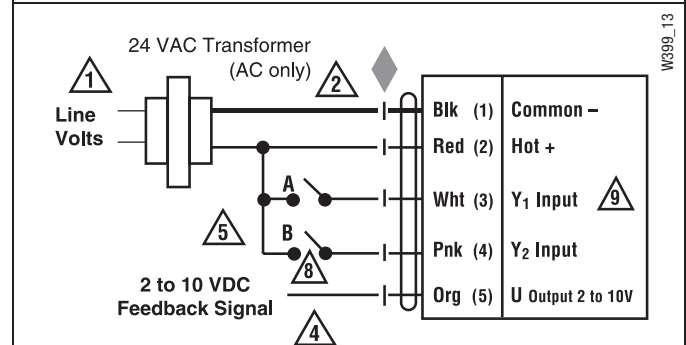

Floating Point control