



ONICON

Flow and Energy Measurement

FT-3000 SERIES

INLINE ELECTROMAGNETIC FLOW METER

The FT-3000 Series family of inline flow meters are designed to provide accurate and reliable flow measurements for a variety of challenging applications in the HVAC market.



We believe in our products, so should you.

1 YEAR NO FAULT WARRANTY
3 YEAR MANUFACTURER WARRANTY



FACTORY CONFIGURED

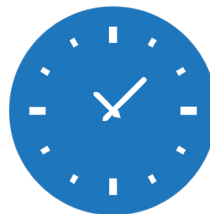

ON TIME DELIVERY



BEST CUSTOMER SERVICE

- Chilled Water • Heating Hot Water • Domestic Water •
- Condenser Water & Water/Glycol Solutions •
- Process Application Water Flow •



Faraday's Law states that a voltage will be induced in a conductor (the conductive fluid) when it passes through a magnetic field (generated by the meter), and that voltage will be directly proportional to the velocity of the conductor (the fluid). This voltage is measured by electrodes on opposite sides of the flow tube and used to calculate the flow velocity.

DESCRIPTION

ONICON FT-3000 Series In-line Electromagnetic Flow Meters are suitable for measuring electrically conductive liquids in a wide variety of applications. The FT-3000 series provides analog and digital outputs for flow rate and programmable pulse outputs for flow totalization and/or alarms.

APPLICATIONS

- HVAC hydronic applications including chilled water, heating hot water and condenser water
- Bi-directional flow for primary/secondary bypass and thermal storage applications
- Domestic cold and hot water applications
- Clean process flow applications with conductivities greater than 5 µS/cm

FEATURES

Exceptional Performance & Accuracy – FT-3000 series inline meters deliver unmatched accuracy in installations with just three diameters of straight pipe upstream of the meter! For limited spaces, the FT-3000 is compliant with zero upstream and downstream straight-run requirements under ISO 4064 test conditions, in accordance with OIML R49.

Easy to Install and Use - Every ONICON meter is individually wet calibrated and programmed for the application - saving start-up and commissioning time!

Excellent Long Term Reliability - ONICON electromagnetic flow meters have no moving parts and employ state-of-the-art electronics, ensuring years of accurate, trouble-free operation.

Multiple Analog Outputs – The FT-3000 series inline meters can be ordered with an additional, redundant analog output for Mission Critical applications.

BAS/BMS Interface Options – The FT-3000 series inline meters include one RS485 or RJ45 connection for native BACnet MS/TP, MODBUS RTU or MODBUS TCP/IP protocols.

CALIBRATION

All FT-3000 series flow meters are wet calibrated in a flow laboratory against standards that are directly traceable to international standards. A certificate of calibration accompanies every meter.



Installing a System-1000 Flow & Energy Measurement System enables integration of multiple FT-3000 series meters into a single display with independent multi-channel energy calculation, expanded measurement points, and enhanced functionality that is tied into the BMS with a single network connection.

SPECIFICATIONS*

FT-3200 TRANSMITTER		
PERFORMANCE	ACCURACY	±0.2% of reading from 1.6 to 33 ft/s ±0.0033 ft/s at flow rates < 1.6 ft/s
	MINIMUM CONDUCTIVITY	5 µS/cm
INPUT POWER**	AVAILABLE OPTIONS	<ul style="list-style-type: none"> • Low Power, 22-26 VAC/DC, 50/60 Hz, 12 VA • High Power, 120 - 240 VAC, 50/60 Hz, 12 VA
I/O SIGNALS**	AVAILABLE OPTIONS	<ul style="list-style-type: none"> • Two (2) digital outputs, one (1) digital input and one (1) analog output • Two (2) digital outputs, one (1) digital input and two (2) analog outputs • MODBUS RTU or BACnet MSTP (RS485) • MODBUS TCP/IP
ELECTRONICS ENCLOSURE**	IP67 (NEMA 4X) painted aluminum enclosure with display	
	AVAILABLE OPTIONS	<ul style="list-style-type: none"> • Integral mount • Remote (wall) mount with kit, up to 325 ft in fluids with conductivity ≥ 200 µS/cm
	DISPLAY	16-character, 8-line, 128x64 graphic backlit LCD
	AMBIENT CONDITIONS	Transmitter: -4°F to 140°F
PROGRAMMING	AVAILABLE OPTIONS	<ul style="list-style-type: none"> • Menu driven user interface via three (3) programming keys • PC user interface via micro USB and downloadable software
ELECTRICAL CONNECTIONS	INPUT POWER	Removable terminal blocks for use with 14 - 22 gauge wire
	I/O SIGNALS	Removable terminal blocks for use with 18 - 24 gauge wire
	COIL & ELECTRODES	Removable terminal blocks for use with sensor cable provided
APPROVALS	CE	2014/30/EU EMC Directive 2014/35/EU LVD Directive

FT-3100 TRANSMITTER		
PERFORMANCE	ACCURACY	±0.4% of reading from 3.3 to 33 ft/s ±0.75% of reading from 1.3 to 3.3 ft/s ±0.0075 ft/s at flow rates less than 1 ft/s
	FLOW PROFILE SENSITIVITY CLASS	U0D0 according to ISO 4064 - OIMLR49 The meter maintains a measurement accuracy of ±0.5% of reading from 0.12 ft/s to 18 ft/s when installed immediately between two elbows.
	MINIMUM CONDUCTIVITY	5 µS/cm
INPUT POWER**	AVAILABLE OPTIONS	<ul style="list-style-type: none"> • Low Power, 22-26 VAC/DC, 50/60 Hz, 12 VA • High Power, 120 - 240 VAC, 50/60 Hz, 12 VA
I/O SIGNALS**	AVAILABLE OPTIONS	<ul style="list-style-type: none"> • Two (2) digital outputs, one (1) digital input, and one (1) analog output • MODBUS RTU (RS485)
ELECTRONICS ENCLOSURE**	IP67 (NEMA 4X) nylon enclosure with display	
	AVAILABLE OPTIONS	<ul style="list-style-type: none"> • Integral mount • Remote (wall) mount with kit, up to 164 ft in fluids with conductivity ≥200 µS/cm
	DISPLAY	16-character, 8-line, 128x64 graphic backlit LCD
	AMBIENT CONDITION	Transmitter: 14°F to 122°F
PROGRAMMING	AVAILABLE OPTIONS	<ul style="list-style-type: none"> • Menu driven user interface via three (3) programming keys • PC user interface via micro USB and downloadable software

* SPECIFICATIONS subject to change without notice.

** See model codification for additional information regarding option selections.

SPECIFICATIONS CONTINUED*

FT-3100 TRANSMITTER (CONT.)		
ELECTRICAL CONNECTIONS	INPUT POWER	Removable terminal blocks for use with 14 - 22 gauge wire
	I/O SIGNALS	Removable terminal blocks for use with 18 - 24 gauge wire
	COIL & ELECTRODES	Removable terminal blocks for use with sensor cable provided
APPROVAL	CE	2014/30/EU EMC Directive 2014/35/EU LVD Directive

FT-3000 SERIES FLOW SENSOR		
PERFORMANCE	SENSING METHOD	Electromagnetic sensing (no moving parts)
OPERATING CONDITIONS	FLUID TEMPERATURE RANGE	See Liner Selection Table Below
	FLUID PRESSURE RANGE	See Liner Selection Table Below
FLOW SENSOR DESIGN**	FLOW TUBE	304 SS
	ELECTRODES	Qty: Three (3), round, 316 SS
FLOW BODY**	AVAILABLE OPTIONS***	<ul style="list-style-type: none"> • Carbon Steel • Stainless Steel • Polypropylene
FLOW LINER**	AVAILABLE OPTIONS***	<ul style="list-style-type: none"> • PTFE • Ebonite • Polypropylene
PROCESS CONNECTIONS**	AVAILABLE OPTIONS	<ul style="list-style-type: none"> • Flanged connections ANSI Class 150 or ANSI Class 300 • Wafer mount • Threaded (NPT) connections (Available for FT-3100 models only)
APPROVALS	NSF CE	61 E97/23/CE PED Directive

* SPECIFICATIONS subject to change without notice.

** See model codification for additional information regarding option selections.

*** Selection based on application.

LINER SELECTION TABLE

Material	Line Size Flanged and Wafer	Grade	Color	Temperature Range	Pressure Range Based on Liner	Abrasion Resistance (Carbon Steel = 100)
Ebonite	8 - 48"	Food	Amber	32°F - 175°F	580 psi (1)	90 - 118
Polypropylene	1 - 6"	Food	Gray	32°F - 140°F	232 psi	122
PTFE	1 - 48"	Food	White	0°F - 266°F (3)	580 psi (1,2)	78
Notes	Description					
1	Flanged meter pressure rating is the lesser of 580 psi or the flange rating.					
2	Wafer style meters above 6" are limited to 232 psi.					
3	Remote mount electronics option required for application temperature above 212°F.					

TYPICAL INSTALLATION IN CONDUCTIVE PIPE

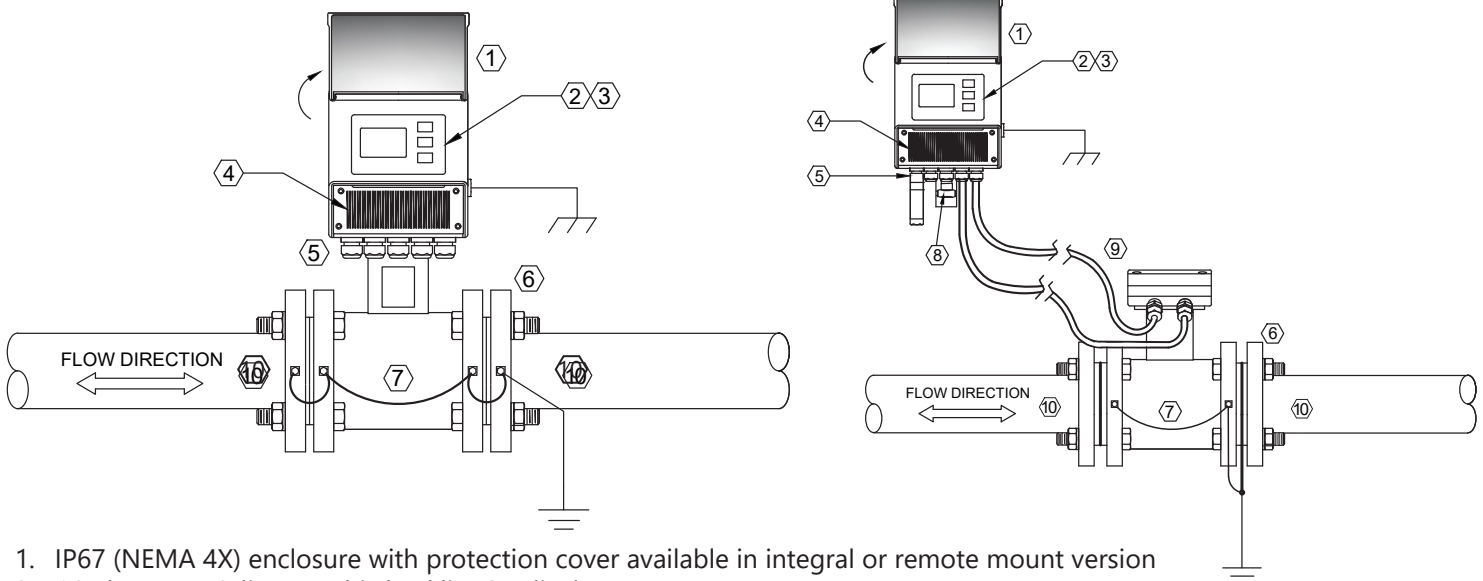

1. IP67 (NEMA 4X) enclosure with protection cover available in integral or remote mount version
2. 16-character, 8-line graphic backlit LCD display
3. Menu driven user interface via three (3) programming keys
4. Wiring connections via plugable terminal blocks located beneath the front access cover
5. Five (5) threaded conduit/ strain relief openings located at the bottom of the enclosure
6. Process connection available in flanged (ANSI Class 150 or ANSI Class 300), wafer or threaded models
7. Flange grounding kit for flanged or wafer versions
8. Remote mount hardware kit
9. Remove mount cable
10. For best results, install the meter with at least 3 pipe diameters of straight run upstream and 2 pipe diameters of straight run downstream. In applications with limited straight run, the FT-3000 series can be installed with zero pipe diameters upstream/ downstream and will perform in accordance to OIML R49 in ISO4064 conditions. Contact ONICON for guidance on the optimal meter installation location.

OPTIONAL GROUNDING RINGS ACCESSORY IN NON-CONDUCTIVE PIPE

Grounding rings are required whenever meters are installed in non-metallic or lined pipes. Grounding rings placed before and after the meter eliminate electrical noise that will interfere with the proper operation of the meter. ONICON provides grounding rings as an optional accessory.

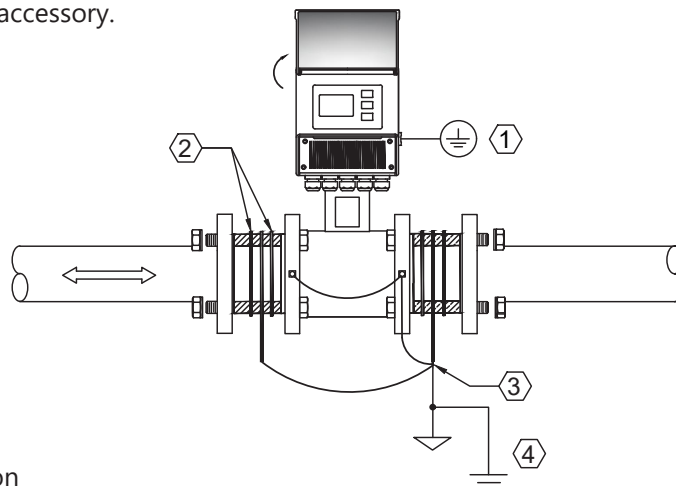

1. Protection ground connection
2. Required gaskets (4pl) to be provided by installing contractor
3. Grounding rings required for non-conductive (non-metallic) or lined pipes (2pl)
4. Earth ground connection

OPERATING FLOW RANGES

THREADED MODELS OPERATING RANGE (Available for FT-31XX models only)		
NOMINAL PIPE SIZE NPS (DN)	FLOW RANGE	
	0.1 ft/s - 33 ft/s	0.03 m/s - 10 m/s
¼" (DN 8)	0.004 - 1.12 GPM	0.01 - 4.24 L/min
⅜" (DN 10)	0.014 - 4.49 GPM	0.05 - 16.99 L/min
½" (DN 15)	0.038 - 12.46 GPM	0.14 - 47.16 L/min
¾" (DN 20)	0.085 - 28.03 GPM	0.32 - 106.1 L/min
1" (DN 25)	0.152 - 49.84 GPM	0.57 - 188.6 L/min

FLANGED AND WAFER MODELS OPERATING RANGE		
NOMINAL PIPE SIZE NPS (DN)	FLOW RANGE	
	0.1 ft/s - 33 ft/s	0.03 m/s - 10 m/s
1" (DN 25)	0.2 - 79 GPM	0.7 - 299 L/min
1½" (DN 40)	0.6 - 203 GPM	2.2 - 768.4 L/min
2" (DN 50)	0.9 - 317 GPM	3.4 - 1,199.9 L/min
2½" (DN 65)	1.6 - 536 GPM	6 - 2,028.9 L/min
3" (DN 80)	2.4 - 812 GPM	9 - 3,073.7 L/min
4" (DN 100)	3.8 - 1,268 GPM	14.3 - 4,799.9 L/min
5" (DN 125)	5.9 - 1,981 GPM	22.3 - 7,498.9 L/min
6" (DN 150)	8.5 - 2,853 GPM	32.1 - 10,799.7 L/min
8" (DN 200)	15 - 5,072 GPM	56.7 - 19,199.6 L/min
10" (DN 250)	24 - 7,925 GPM	90.8 - 29,999 L/min
12" (DN 300)	34 - 11,412 GPM	128.7 - 43,199.1 L/min
14" (DN 350)	47 - 15,533 GPM	177.9 - 58,798.8 L/min
16" (DN 400)	61 - 20,288 GPM	230.9 - 76,798.4 L/min
18" (DN 450)	77 - 25,678 GPM	291.4 - 97,201.8 L/min
20" (DN 500)	95 - 31,701 GPM	359.6 - 12,0001 L/min
24" (DN 600)	137 - 45,649 GPM	518.6 - 172,800 L/min
30" (DN 750)	210 - 69,185 GPM	794.9 - 261,894 L/min
36" (DN 900)	304 - 100,479 GPM	1,150.7 - 380,354 L/min
40" (DN 1000)	378 - 124,577 GPM	1,430.8 - 471,575 L/min
42" (DN 1050)	417 - 193,800 GPM	1,578.5 - 733,613 L/min
48" (DN 1050)	547 - 182,596 GPM	2,070.6 - 691,201 L/min

METER ORDERING INFORMATION

FT-3000 Meter Model Number Codification = FT-3AGG-HIJKL-BCDE-(SPC)

FLOW SENSOR CONFIGURATION INFORMATION

A = Transmitter Series

- 1 = Basic Transmitter (0.4% Accuracy)
- 2 = Advanced Transmitter (0.2% Accuracy)

GG = Meter Size (inches)

Flanged and Wafer Models

- | | | | |
|----------|----------|---------|-------------------------------------|
| 01 = 1" | 25 = 2½" | 05 = 5" | 10 = 10" |
| 15 = 1½" | 03 = 3" | 06 = 6" | nn = Meter Size, 12 - 24" (FT-31XX) |
| 02 = 2" | 04 = 4" | 08 = 8" | 12 - 48" (FT-32XX) |

Threaded Models (FT-31XX Only)

- | | | |
|---------|---------|---------|
| AA = ¼" | AC = ½" | AE = 1" |
| AB = ⅜" | AD = ¾" | |

H = Liner Material

- 1 = PTFE
- 2 = Polypropylene
- 3 = Ebonite

I = Process Connection

- 0 = Wafer connection
- 1 = ANSI 150 flanges
- 3 = ANSI 300 flanges
- A = NPT thread (FT-31XX only)

JK = Body Material

- 11 = Carbon Steel w/ SS Electrodes
- 41 = 304 SS w/ SS Electrodes
- 51 = 316 SS w/ SS Electrodes
- 91 = Polypropylene w/ SS Electrodes

L = Electronics Enclosure Mounting Configuration

- 1 = Integral
- 2 = Remote

TRANSMITTER CONFIGURATION INFORMATION

BC = Outputs

- 10 = One (1) AO, two (2) DO and one (1) DI
- 11 = One (1) AO, two (2) DO and one (1) DI w/ MODBUS RTU (RS485) (FT-31XX only)
- 21 = Two (2) AO, two (2) DO and one (1) DI w/ BACnet MS/TP or MODBUS RTU (RS485) (FT-32XX only)
- 22 = Two (2) AO, two (2) DO and one (1) DI w/ MODBUS TCP/IP (FT-32XX and 24 VDC only. E = 1)

D = Electronics Enclosure

- 1 = IP67 (NEMA 4X) nylon enclosure w/ display (FT-31XX only)
- 2 = IP67 (NEMA 4X) painted Al enclosure w/ display (FT-32XX only)

E = Input Power

- 1 = Low power, 22-26 VAC/VDC
- 2 = High power, 120 - 240 VAC

SPC = Special Configurations

- 101 = 4GB SD Memory, RTC (FT-32XX only)

